

IBC TOTE SCALE

FOR CHEMICAL IBC TOTES

Safely track
chemical usage
and amount
remaining

Warn of dangerous
over and under-
feed conditions

Help prevent
system from
running empty

4-20mA remote
monitoring reduces
operator exposure
to chemicals

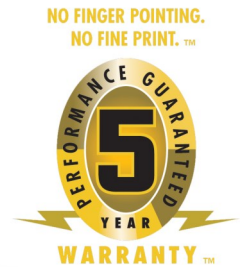

Strict federal and state reporting requirements have created a need for water and wastewater plant operators to easily and accurately track chemical feed rates and usages. The IBC Tote Scale gives you this information along with the assurance that your chemical supply will not unexpectedly run out.

The heavy duty steel platform is protected with our advanced 80 mil thick TUF-COAT™ Environmental Armor. TUF-COAT is highly resistant to chemicals, abrasion, impact and ultraviolet light degradation making the IBC Tote Scale ideal for even the harshest environments. Options include 316 stainless steel and MaxSense™ high accuracy models.

The IBC Tote Scale utilizes weighing technology to create a highly reliable, non-contacting chemical monitoring system that avoids problems other sensor technologies face caused by irregular tank shapes, corrosive chemical fumes, fluctuating temperatures and changes in specific gravity.

SpillSafe Tote Scale
with integral
containment
See Bulletin 423



FORCE FLOW

IBC TOTE SCALE

MODELS AND ORDERING INFORMATION

IBC Tote Scales do not include weight indicating instrument. Select from the following: Wizard 4000™ Advanced Digital Display (Bulletin 400), the SOLO G2™ Digital Weight Display (Bulletin 516), the SOLO XT™ Hydraulic Digital Display (Bulletin 514), the Century™ Hydraulic dial (Bulletin 519) or Hypo Trak™ (Bulletin 517). Please order indicator separately.

ELECTRONIC - Single Load Cell Platform (Includes platform with backstop and electronic load cell with 20 ft. cable. Lengths up to 100 ft available; request when ordering. TUF-COAT™ is an 80 mil thick polyurea-based coating system highly resistant to wear & chemicals)

MODEL	MATERIAL	X	Y	Z	H	ACCURACY
50-DR××TB	TUF-COAT STEEL	50.5"	50.5"	54.5"	3.25"	1/4 of 1% FS
50-DR××TBS	316 STAINLESS STEEL	50.5"	50.5"	54.5"	3.25"	1/4 of 1% FS
54-DR××TB	TUF-COAT STEEL	54"	54"	58"	3.25"	1/4 of 1% FS
54-DR××TBS	316 STAINLESS STEEL	54"	54"	58"	3.25"	1/4 of 1% FS
60-DR××TB	TUF-COAT STEEL	60"	60"	64"	3.25"	1/4 of 1% FS
60-DR××TBS	316 STAINLESS STEEL	60"	60"	64"	3.25"	1/4 of 1% FS

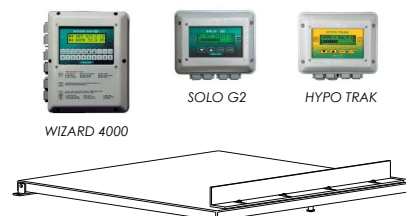

ELECTRONIC - High Accuracy 4-Load Cell Platform (Includes platform and (4) electronic load cells with 20 ft. of cable. Lengths up to 100 ft available upon request. Backstop not included or necessary on these models but available upon special request.)

MODEL	MATERIAL	X	Y	Z	H	ACCURACY
50-DR××TBHA4	TUF-COAT STEEL	50.5"	50.5"	N/A	3.25"	1/10 of 1% FS
50-DR××TBSHA4	316 STAINLESS STEEL	50.5"	50.5"	N/A	3.25"	1/10 of 1% FS
54-DR××TBHA4	TUF-COAT STEEL	54"	54"	N/A	3.25"	1/10 of 1% FS
54-DR××TBSHA4	316 STAINLESS STEEL	54"	54"	N/A	3.25"	1/10 of 1% FS
60-DR××TBHA4	TUF-COAT STEEL	60"	60"	N/A	3.25"	1/10 of 1% FS
60-DR××TBSHA4	316 STAINLESS STEEL	60"	60"	N/A	3.25"	1/10 of 1% FS

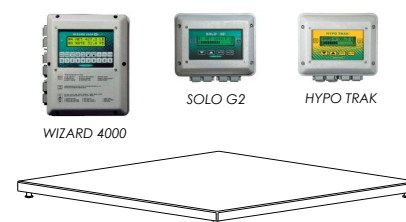

HYDRAULIC - Single Load Cell Platform (Includes platform with backstop, and hydraulic load cell with 12 ft. Hose and quick connect. Hose/tubing lengths up to 100 ft available to allow remote mounting of indicator; request at time of purchase.)

MODEL	MATERIAL	X	Y	Z	H	ACCURACY
50-HY××TB	TUF-COAT STEEL	50.5"	50.5"	54.5"	3.25"	1/2 of 1% FS
50-HY××TBS	316 STAINLESS STEEL	50.5"	50.5"	54.5"	3.25"	1/2 of 1% FS
54-HY××TB	TUF-COAT STEEL	54"	54"	58"	3.25"	1/2 of 1% FS
54-HY××TBS	316 STAINLESS STEEL	54"	54"	58"	3.25"	1/2 of 1% FS
60-HY××TB	TUF-COAT STEEL	60"	60"	64"	3.25"	1/2 of 1% FS
60-HY××TBS	316 STAINLESS STEEL	60"	60"	64"	3.25"	1/2 of 1% FS



×× = CAPACITY: 1000 lbs = "10", 2000 lbs = "20", 3000 lbs = "30", 4000 lbs = "40", 5000 lbs = "50"

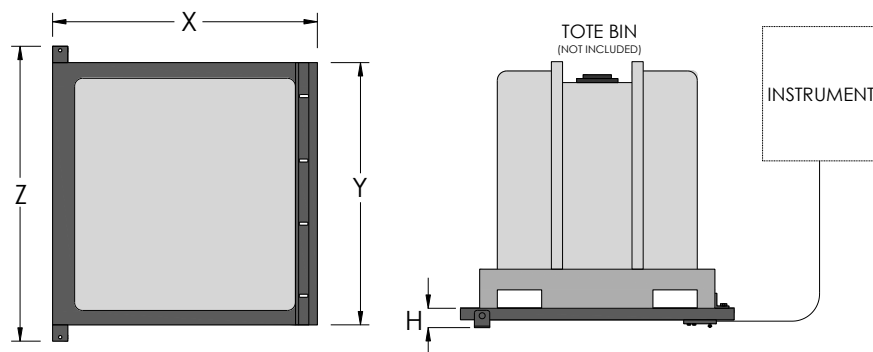

SPECIFYING GUIDELINES:

- For maximum accuracy, size scale capacity to match the gross weight (chemical plus tote tare weight).
- Tote size should not exceed platform size.
- Supply connections must be flexible and preferably connected to tote over pivoted side of platform.

Please visit www.forceflowscales.com for drawings, engineered specifications and manuals.

FORCE FLOW