



High-Tech Commercial Pool Disinfection with Powerful Performance

The CCH® Elite feeder is a high capacity erosion (HCE) feeder that is compact and lightweight with a modular design. The feeder uses CCH® 1” calcium hypochlorite tablets that work in conjunction to produce a fresh concentrated liquid chlorine solution for clean and sanitized water. This innovative feeder system is easy to maintain and service with a flexible design that allows for easy integration for small to large commercial pools.

Switch to the CCH® Elite Feeder System, delivering clear and sparkling water time and time again!

Powerful Feeder Performance

- Provides consistent chlorine delivery
- Feeder designed to minimize maintenance requirements
- 2 in 1 dust reduction funnel for loading tablets with capacity extension
- Rotomolded components hold up to the strongest elements
- Feeder design allows for easy access to internal components
- Features high capacity erosion technology with the benefits of a venturi and booster pump

Tablet Efficiencies

- Won't overstabilize pool
- More concentrated than liquid bleach
- Dry, easy to handle formulation
- Will not cause reduction of ORP
- Highly concentrated to reduce shipping and handling costs
- Longer shelf life when compared to liquid bleach

A 3-in-1 product that chlorinates consistently, increases calcium to protect plaster and balances alkalinity to stabilize pH!





Feeder Specifications

Width	25.3"	642.62mm
Depth	29.8"	756.92mm
Height	40.9"	1038.89mm
Water Inlet Size	1/2" MNPT	12.7mm MNPT
Solution Outlet Size	1/2" MNPT	12.7mm MNPT
Operating Weight	220lbs	99.7kg
Shipping Weight	60lbs	27.7kg
Dry Chemical Capacity	90 – 135lbs*	40.82 – 61.23kg*
Feed Rate Range – Pool	5 – 127 lbs AvCL/day	2.3 – 57.6 kg AvCL/day
Feed Rate Range – Spa	5 – 135 lbs AvCL/day	2.3 – 61.2 kg AvCL/day
Electrical	115VAC	
Operating Temperature	40° – 120° F	4.4° – 35°C

*Higher capacity with inverted bucket placed into top funnel

Tablet Specifications

Active Ingredient	Calcium Hypochlorite	
Available Chlorine	68%	
Weight	40g	
Chemical Form	Tablet	
Diameter	1"	25.4mm
Color	White	
Container	Pail	
Container Weight	45lbs	20.4kg

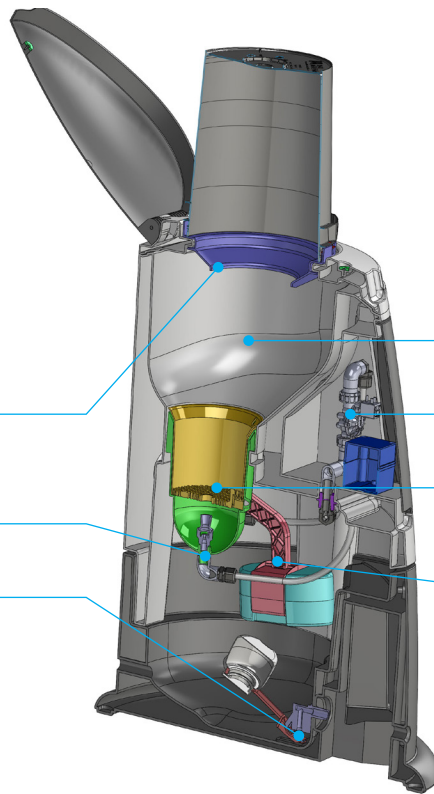

Hopper

Enhanced hopper attachment

allows for added chemical capacity and reduction in dust during chemical loading

Dual solenoids minimize solid build up

Tablet grid

Removable for easy maintenance

High capacity erosion nozzle

Durable discharge valve

Emergency shut-off valve to prevent spills